

TORUS SLAT WOOD WALL & CEILING PANELS

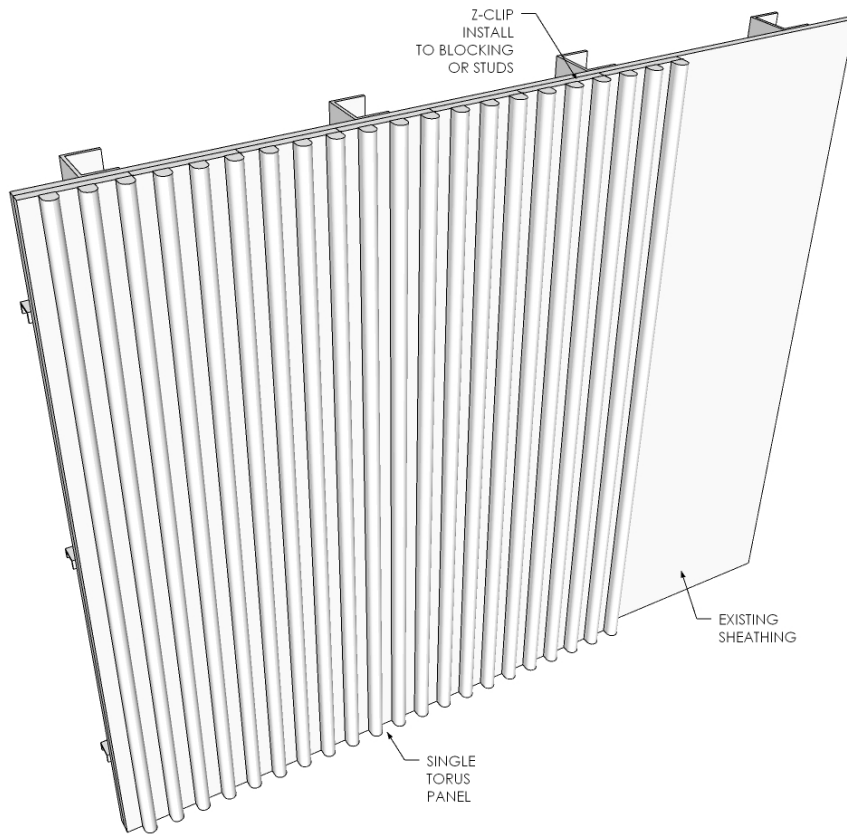

PRODUCT SPECIFICATIONS

SLAT DIMENSIONS	Overall standard thickness is 11/16" Panels include a 3/4" thick nominal veneered backer (11/16") Standard individual slat size is 1" face, 1" visible depth (1 1/16" depth, routed 1/16" into backer)
PANEL WIDTH	Panel supplied up to 4' maximum Can be butted together seamlessly
PANEL HEIGHT	Standard height is 8' Up to 10' available (price increase)
MINIMUM	100sf for 2' and/or 4' x 8' panels 200sf for custom size panels
FINISH	Unfinished or prefinished <i>see next page</i>
INSTALLATION	Typically installed with Z clips <i>see next page</i>
CUSTOM	Custom slat and panel sizes available

NOTE: Pricing of all solid wood and veneer products experience fluctuations. Please reach out for current pricing for your specific project.

TORUS SLAT WOOD WALL & CEILING PANELS

PRODUCT DATA

Description: Three-dimensional wall and ceiling panels with solid wood slats and veneer backer on MDF as manufactured by Urban Evolutions, Inc.

Species Options: Select White Oak, Select Walnut, Select Ash, Select Douglas Fir, Select Paint Grade Poplar

Source Options: Domestic Timber, Felled City Trees (Urban Wood)

Dimensions: 4'x8' panels (standard)

Weight: 3.75 - 4lbs per SF

Core: 11/16" MDF, NAF, TSCA Title VI Compliant, Class A Fire Rated and/or FSC Certified Core available on request

Finish Options: All standard finishes are Class A Fire Rated. [Click here for more information.](#)

Additional Options: Trim and corner pieces available for an additional charge. Unfinished slatted wall panels are available upon request.

Site Conditions

For most installations, we recommend a climatic temperature between 55 to 75 degrees Fahrenheit and 30% to 50% humidity level. Environments that do not meet these criteria will cause wood to experience shrinking and swelling issues that damage the product. We cannot guarantee our product's performance in such environments.

Installation

Installation materials are not included and must be purchased separately. For wall installation, we recommend using MF375 Monarch Z-Clips. For ceiling installations, we recommend using MFCEIL-H Monarch Ceiling Clips. Please reach out to the hardware manufacturer for specific project considerations.

Grain and Allowances

Natural color and grain variation occur across panels. White Oak and Walnut panels may include sapwood up to 10% of total panel. Small, sound pin knots may occur in solid wood slats.

LEED

Urban Evolutions veneer panels may contribute toward satisfying the following credits under LEED® v4.1:

M&R – Material Ingredient Reporting – Declare Label

M&R – Sourcing of Raw Materials – Material Reuse (Urban Wood)

IEQ – Low-Emitting Materials – VOC Emissions Evaluation

IEQ – Low-Emitting Materials – Formaldehyde Emissions Evaluation (MDF)

TORUS SLAT WOOD WALL & CEILING PANELS

PRODUCT IMAGES

Slat Dimensions

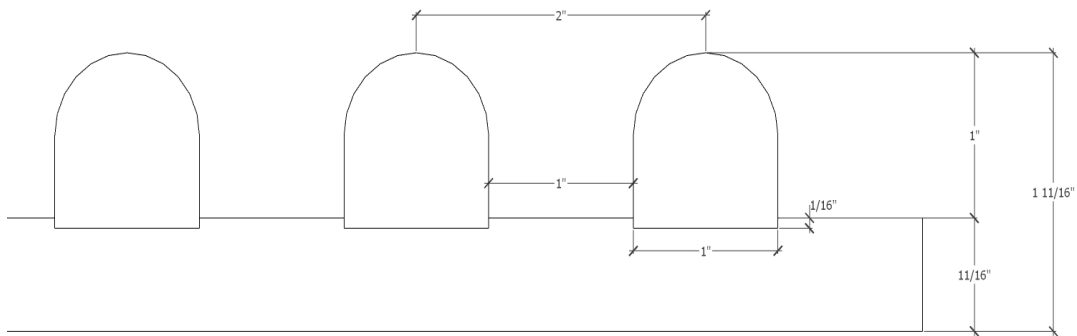

Corner Pieces Top View

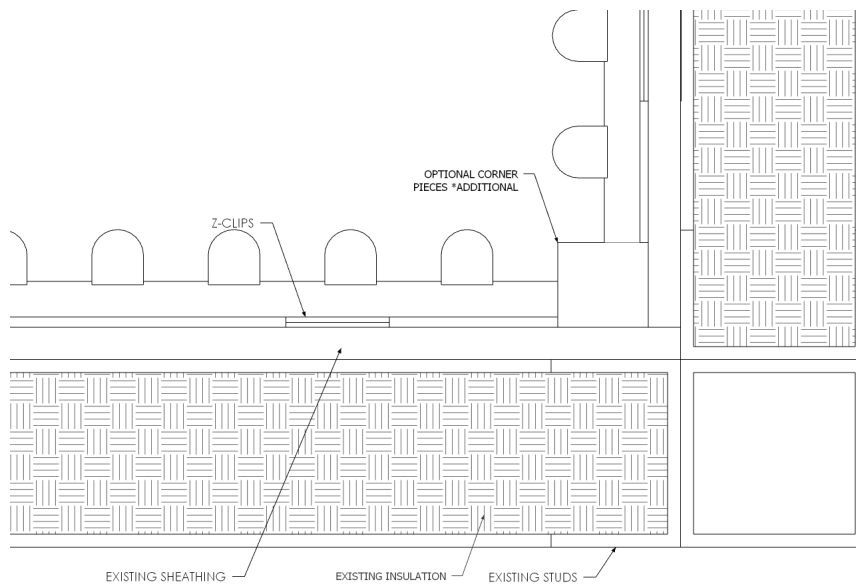

TORUS SLAT WOOD WALL & CEILING PANELS

PRODUCT IMAGES

Edge Piece Top View

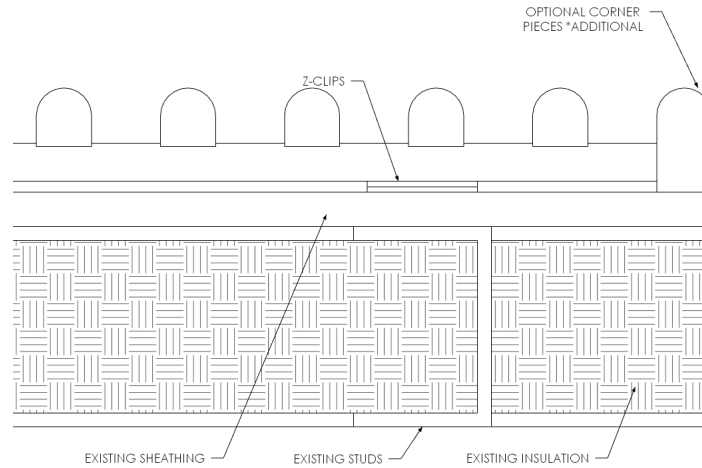

Veneer Edge Top View

